

ILO CONSTRUCTION OS&H

A free, comprehensive, international, digital training package in occupational safety and health for the construction industry

THEME SUMMARY 10: GENERAL PLANT & EQUIPMENT



(Photo: Richard Neale, permission given by operators)

Summary of content	
1.	Preface
2.	Common hazards with general plant and equipment
3.	General construction plant and equipment
4.	Hand tools
5.	Scaffolding materials and equipment
6.	Temporary works for concrete and steel
7.	Trench support and excavation equipment
8.	Fire prevention and control equipment
9.	Electricity
10.	Relevant elements of the Knowledge Base

1 PREFACE

Most of this Theme is relevant to those who purchase, install, maintain and inspect plant and equipment, rather than those who use it in the construction process. The use of the plant and equipment is described in Theme Summaries: 11 “Vertical movement”, 12 “Horizontal movement”, 13 “Working at or below ground level” and 14 “Working at height”.

OS&H and construction plant and equipment has to be considered within the overall context of a construction project. The following is a good example, taken from a project in Australia, the Pacific Highway, Karuah to Bulahdelah sections 2 and 3 (http://www.k2b.abigroup.com.au/html/safety_b.html). The ILO is very grateful to the RTA for permission to use this example.

“The Pacific Highway Upgrade Program is one of the largest infrastructure projects in New South Wales (NSW) history. From the F3 Freeway to the Queensland border, the NSW State and Federal governments are working together to build a safer and better highway. Accident-prone sections are being replaced with median-separated dual carriageways, and sections with major traffic congestion are gradually being improved. The RTA is managing the program with a view to achieving a balance between social, ecological, engineering and cost factors, while providing adequately for the future transport needs of highway users and NSW central coast communities.

Occupational health and safety is a primary consideration in the planning and organisation of the project’s operations.

The project involves many different activities from earthworks to bridges and encompasses road users, workers and residents. By identifying the potential major hazards associated with the different activities on site, it is possible to reduce the risk of injury to employees, public and damage to equipment. Strategies include:

- *To plan each stage of the project with safe working as one of the primary objectives.*
- *To ensure the appropriate equipment is used for each operation including the provision of protective clothing.*
- *To encourage everyone to work together in developing and maintaining safety.*
- *To provide adequate training and instruction.*
- *To ensure adequate supervision.*
- *To maintain adequate records and undertake full accident investigations.*
- *To provide full feedback information to all participants.*

Hazards identified for the project include:

- *Construction plant (large machines and continuous activity).*
- *Existing services (high voltage, fibre optic cable, etc).*
- *Piling (large cranes, heavy materials).*
- *Bridge construction.*
- *Terrain (steep slopes).*
- *Adjacent traffic on public roads, including intersections.*
- *The mixing of construction plant and traffic.*
- *Working at heights.*

Risk management is integral to the project and its evaluation and assessment play a significant role. Detailed processes require each major activity and sub-activity associated with the works to be given a risk rating. This is the catalyst for the subsequent development of safe work procedures which are documented on job hazard analysis (JHA) worksheets. Regular training is provided to give work crews and supervisors help in the development and understanding of these worksheets and risk management.”

This Theme Summary follows the relevant structure and content of the “ILO Code of Practice: Safety & health in construction” (the “Code”). The following passage is taken from this Code:

“1. General provisions

1.1. Objective

1.1.1. The objective of this code is to provide practical guidance on a legal, administrative, technical and educational framework for safety and health in construction with a view to:

- (a) preventing accidents and diseases and harmful effects on the health of workers arising from employment in construction;*
- (b) ensuring appropriate design and implementation of construction projects;*
- (c) providing means of analysing from the point of view of safety, health and working conditions, construction processes, activities, technologies and operations, and of taking appropriate measures of planning, control and enforcement.*

1.1.2. This code also provides guidance in the implementation of the provisions of the Safety and Health in Construction Convention, 1988 (No. 167), and the Safety and Health in Construction Recommendation, 1988 (No. 175).”

Other passages from this Code are included in this Theme Summary, and they are shown in the same format as above.

This Theme Summary also includes extracts from the ILO’s “Safety, health and welfare on construction sites: A training manual” (“The Manual”). Further details of this manual and the Code are given in Section 10 below: Relevant elements of the Knowledge Base.

This Theme Summary follows the sections shown in the table above.

2 COMMON HAZARDS WITH GENERAL PLANT AND EQUIPMENT

Modern construction plant and equipment should create no hazards for anyone on a construction project. Many of the hazards which do arise have the following causes:

- Poor mechanical design (breaks in use, not powerful enough, components fracture or malfunction)
- Poor functional design (not properly designed for the stated purpose)
- Misuse (not used as designed)
- Used in the wrong circumstances (e.g. ground collapses under a crane)
- Poor maintenance (breaks or emits noxious gases)

These can cause the following hazards:

- Falling machinery or parts of machinery
- Crushing due to impact of moving or toppling plant and equipment
- Falling from plant and equipment
- Limbs or bodies caught in machinery
- Physiological damage through vibration
- Poor ergonomics
- Physiological and psychological damage through repetitive work
- Stress caused by poor environment (noise, heat, poor ventilation, chemicals, noxious gases)

These are, of course, just some of the main hazards; there are many more which are specific to particular projects.

3 GENERAL CONSTRUCTION PLANT AND EQUIPMENT

Moving plant and equipment

6.1.1. All vehicles and earth-moving or materials-handling equipment should:

(a) be of good design and construction taking into account as far as possible ergonomic principles, particularly with reference to the seat;



(Photo: Robert Carr, <http://myconstructionphotos.smugmug.com>)

(b) be maintained in good working order;

6.1.9. Where appropriate, earth-moving or materials-handling equipment should be fitted with structures designed to protect the operator from being crushed, should the machine overturn, or from falling material.



“Roll Over Protection System or ROPS are designed and fitted to machinery which on overturning would reduce the possibility of an operator from being crushed, provided the operator was wearing a seat belt. The following points must be taken into account when operating plant with a Roll Over Protection System.

Ensure that seat belts are worn in conjunction with ROPS protection; otherwise there is a risk that the driver may be crushed by the ROPS bar as he or she is thrown from the vehicle.”

(Photo and text from “Use of Mobile Machinery on Construction Sites” Published June 2008 by Health and Safety Authority, James Joyce Street, Dublin 1, Ireland. <http://www.hsa.ie>. The ILO is very grateful for permission to use this information)

6.1.10. All vehicles and earth-moving or materials-handling equipment should be provided with a plate or the like indicating:

(a) the gross laden weight;

(b) the maximum axle weight or, in the case of caterpillar equipment, ground pressure;

(c) the tare weight.

6.1.11. All vehicles and earth-moving or materials-handling equipment should be equipped with:

(a) an electrically operated acoustic signalling device;

(b) searchlights for forward and backward movement;

(c) power and hand brakes;

(d) tail lights;

(e) silencers;

(f) a reversing alarm.

The following table is taken from “Use of Mobile Machinery on Construction Sites” Published June 2008 by Health and Safety Authority, James Joyce Street, Dublin 1, Ireland. The ILO is grateful for permission to use this table and other quotations from this Authority.

The Authority’s web site http://www.hsa.ie/eng/Publications_and_Forms/Publications provides some excellent information and much of it can be downloaded freely.

Safety Devices			
Auxiliary Devices / Visual Aids			
Where an operator's view is restricted from his position in the driver's seat auxiliary devices / visual aids (as listed below) must be installed unless a risk assessment shows that they are not required. The purpose of these auxiliary devices and visual aids is to allow vision from the driver's seat of all points more than 1 meter high and 1 meter from the machine at each side and at the rear of the driver. Auxiliary devices also give warning to persons who maybe in the vicinity of mobile plant & machinery.			
Table 2-Abbreviated Schedule 6			
Machine type	Reversing & visual aids required	Machine type	Reversing & visual aids required
Off-road dump trucks (Trailer to rear of driver) > 7 tonnes	Reversing alarm and flashing beacon with CCTV or convex mirrors or a combination of both	Scrapers	Reversing alarm and flashing beacon with CCTV or convex mirrors or a combination of both
Dumpers (front tip) no cab	Reversing alarm and flashing beacon	All tracked type tractors (bulldozers)	Reversing alarm and flashing beacon with CCTV or convex mirrors or a combination of both
Dumpers (front tip) with cab	Convex mirrors; reversing alarm and flashing beacon	Graders	CCTV, convex mirrors, reversing alarm and flashing beacon
Wheel Loaders (loading shovels), including skid steer loaders	Reversing alarm and flashing beacon with CCTV or convex mirrors or a combination of both	Telescopic Handlers	Reversing alarm and flashing beacon with CCTV or convex mirrors or a combination of both
Backhoe Loaders	Convex mirrors; reversing alarm and flashing beacon	Compactors / rollers without cab and seat to rear	Reversing alarm & flashing beacon
All 360° excavators	Movement alarm and flashing beacon with CCTV or convex mirrors or a combination of both to allow vision from drivers seat (without slewing)	Compactors / rollers with cab and seat to rear	Convex mirrors; reversing alarm and flashing beacon

6.1.12. Operators of vehicles and earth-moving or materials-handling equipment should be adequately protected against the weather or accidents due to impact, crushing or contact with a moving load by a cab:

(a) which is designed and constructed in accordance with ergonomic principles and provides full protection from adverse weather conditions;

(b) which is fully enclosed where dusty conditions are likely to be encountered;

(c) which provides the driver with a clear and unrestricted view of the area of operation;

(d) which is equipped with a direction indicator and a rear-view mirror on both sides.

6.1.13. *The cab of vehicles and earth-moving or materials-handling equipment should be kept at least 1m from a face being excavated.*



(Photo: Robert Carr, <http://myconstructionphotos.smugmug.com>)

6.1.15. *On earth-moving and materials-handling equipment, motors, brakes, steering gear, chassis, blades, blade-holders, tracks, wire ropes, sheaves, hydraulic mechanisms, transmissions, bolts and other parts on which safety depends should be inspected daily.*

6.1.17. *Deck plates and steps of vehicles and equipment should be kept free from oil, grease, mud or other slippery substances.*

Power shovels and excavators

6.2.2. *Brake pedals for all motions on power shovels should have two independent locking devices.*

6.2.3. *Power shovels should be equipped with an emergency quick-acting stop device independent of the controls.*

6.2.4. *Excavators that are equipped with a unit for deep digging should either be so designed that the bucket teeth cannot come nearer the boom than 40cm or be provided with a reliable stop that prevents this from happening.*

6.2.5. *Excavators that are designed to be used for lifting with lifting gear should be provided with a plate in the cabin and on the boom bearing a clearly legible and durable text giving the maximum safe working load of the lifting gear fitted.*

6.2.6. *Excavators that are equipped for use as mobile cranes should:*

(a) be examined and tested in accordance with national laws and regulations for mobile cranes;

(b) be fitted with an automatic safe working load indicator, when practicable.



(Image: <http://www.cpa.uk.net/data/uploads/public/CIG%200801%20Excavators%20Used%20as%20Cranes-Rev%20-%20March%202009.pdf>)

Note that great care must be taken when using excavators as mobile cranes. They have, generally, not been designed as cranes and have very different operating characteristics. For a full explanation see “UK CPA Guidance on Lifting Operations in Construction When Using Excavators”, available from the cpa web site given above. Under no circumstances should they be used for lifting people, their operating characteristics make this extremely dangerous. The ILO is very grateful to the CPA for permission to use the image above.

6.2.18. While work is being done on hydraulically operated buckets the piston should be fully drawn back in the hydraulic cylinder, and where necessary props provided.

Pavers

Pavers are very complex items of machinery and require great skill to maintain safely. All those involved must be properly and thoroughly trained.



(Photo: Richard Neale. Permission given by the operator)

6.6.1. Pavers should be equipped with guards that prevent workers from walking under the skip.

Note also that health hazards may occur from breathing the fumes from the asphalt, to which operators are especially exposed because they sit over the hot asphalt. Their health should be monitored regularly and carefully.

Lifting appliances and gear



(Image: <http://www.cpa.uk.net>. The ILO is very grateful to the cpa for permission to use this image)

5.1.1. Employers should have a well-planned safety programme to ensure that all the lifting appliances and lifting gear are selected, installed, examined, tested, maintained, operated and dismantled:

(a) with a view to preventing the occurrence of any accident;

(b) in accordance with the requirements laid down in the national laws, regulations and standards.

5.1.2. Every lifting appliance, including its constituent elements, attachments, anchorages and supports should be of good design and construction, of sound material and have adequate strength for the purpose for which it is used.

All cranes should be fitted with a safety hook designed to prevent accidental dislodgement of the load if it fouls something or meets an obstruction during the lift. There is a range of different safety hooks, each with its specific characteristics.

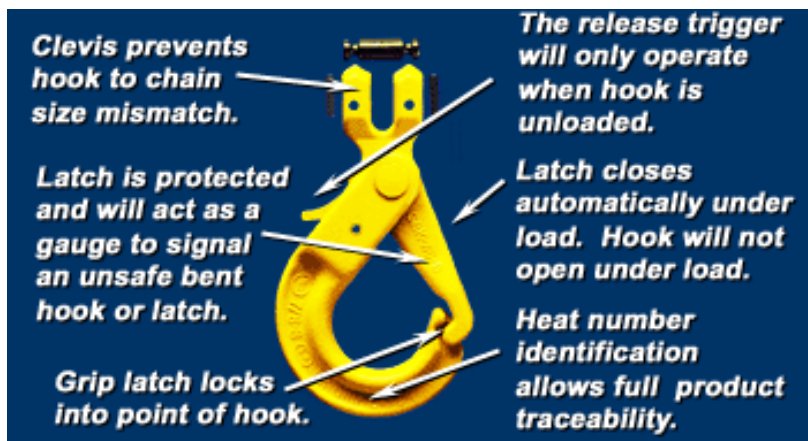

[Images from <http://meerholz.ca>. The ILO is very grateful to Meerholz for permission to use these images.]

5.1.3. Every lifting appliance and every item of lifting gear should be accompanied at the time of purchase with instructions for use and with a test certificate from a competent person or a guarantee of conformity with national laws and regulations concerning:

(a) the maximum safe working load;

(b) safe working loads at different radii if the lifting appliance has a variable radius;

(c) the conditions of use under which the maximum or variable safe working loads can be lifted or lowered.

5.1.4. Every lifting appliance and every item of lifting gear having a single safe working load should be clearly marked at a conspicuous place with the maximum safe working load in accordance with national laws and regulations.

5.1.5. Every lifting appliance having a variable safe working load should be fitted with a load indicator or other effective means to indicate clearly to the driver each maximum safe working load and the conditions under which it is applicable.

Modern load sensors provide a very good and reliable means of informing the user of the weight about to be lifted and provide clear warning when the safe load is about to be exceeded. The most modern are wireless, so eliminating the work of wiring the indicators into the lifting appliance, and also eliminating subsequent risks of damage and corrosion. There is no excuse therefore for ‘accidents’ when lifting excessive loads.

An example of a modern load monitoring system, by Cranesmart (<http://www.cranesmart.com>) is shown below. This is a very helpful company and their web site provides some very useful information.

777 Multi-line load cell installation and placement guide for load cell links

Figure 'A' - Pin the BLUE load cell between the wire rope socket (becket) and the dead end on the main boom of the crane. >MAIN<

Figure 'B' - Pin the YELLOW load cell between the wire rope socket (becket) and the headache ball on the auxiliary sheave (rooster) on the cranes boom tip. >AUX 1< (Note: for two line load systems only)

Figure 'C' - Pin the ORANGE load cell between the wire rope socket (becket) and the headache ball on the jib extension. >AUX 2< (Note: for three line load systems only)

Figure 'D' - Location of external magnetic mount antenna on operator cab of crane.

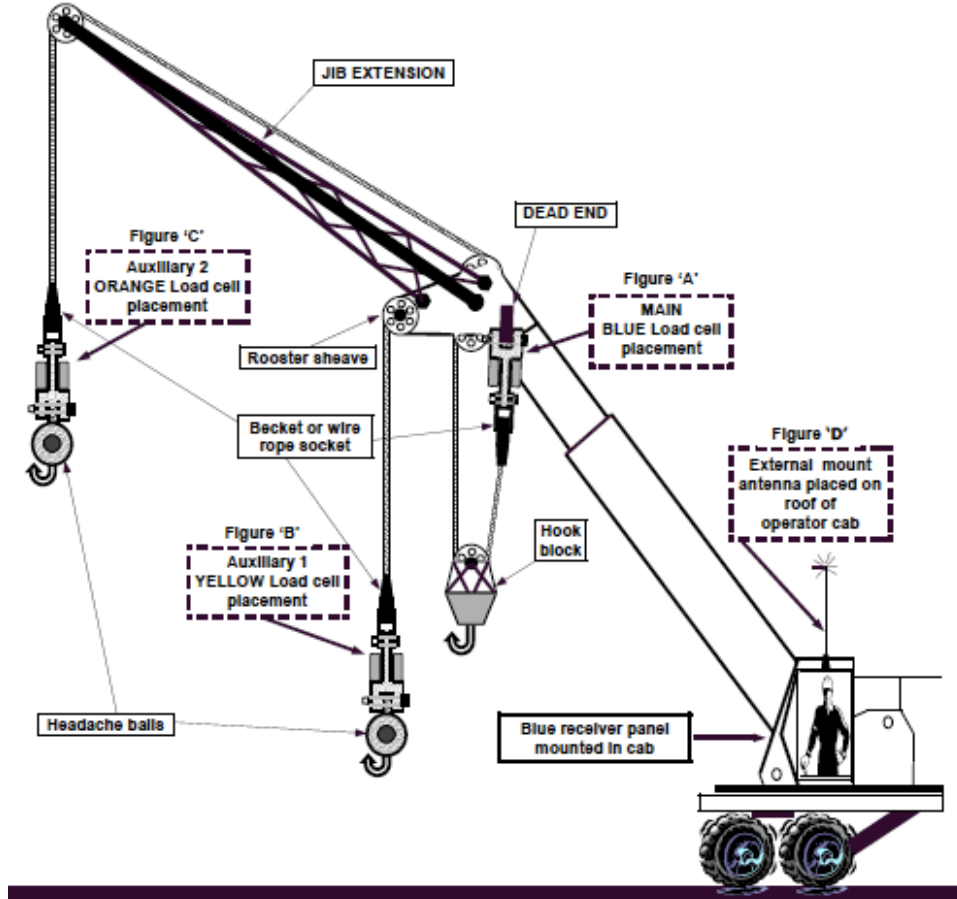

All the information from the load cells comes to the driver on one device, giving clear and useful information:



5.1.6. All lifting appliances should be adequately and securely supported; the weight-bearing characteristics of the ground on which the lifting appliance is to operate should be surveyed in advance of use.

5.1.7. Fixed lifting appliances should be installed:

- (a) by competent persons;*
- (b) so that they cannot be displaced by the load, vibration or other influences;*
- (c) so that the operator is not exposed to danger from loads, ropes or drums;*
- (d) so that the operator can either see over the zone of operations or communicate with all loading and unloading points by telephone, signals or other adequate means.*

5.1.9. The strength and stability of lifting appliances should take into account the effect of any wind forces to which they may be exposed.

5.1.10. No structural alterations or repairs should be made to any part of a lifting appliance which may affect the safety of the appliance without the permission and supervision of the competent person.

5.1.11. Lifting appliances and items of lifting gear, as prescribed by national laws or regulations, should be examined and tested by a competent person:

- (a) before being taken into use for the first time;*
- (b) after erection on a site;*
- (c) subsequently at intervals prescribed by national laws and regulations;*
- (d) after any substantial alteration or repair.*

5.1.12. The manner in which the examinations and tests are to be carried out by the competent person and the test loads to be applied for different types of lifting appliances and lifting gear should be in accordance with national laws and regulations.

5.1.13. The results of the examinations and tests on lifting appliances and lifting gear should be recorded in prescribed forms and, in conformity with national laws and regulations, made available to the competent authority and to employers and workers or their representatives.

5.1.14. Controls of lifting appliances should be:

- (a) designed and constructed as far as possible in accordance with ergonomic principles;*
- (b) conveniently situated with ample room for operation and an unrestricted view for the operator;*

(c) provided, where necessary, with a suitable locking device to prevent accidental movement or displacement;

(d) in a position free from danger from the passage of the load;

(e) clearly marked to show their purpose and method of operation.

5.1.15. Lifting appliances should be equipped with devices that would prevent the load from over-running and prevent the load from moving if power fails.

5.1.16. The operator of every lifting appliance used outdoors except those used for short periods should be provided with:

(a) a safe cabin with full protection from weather and adverse climatic conditions, and designed and constructed in accordance with ergonomic principles;

(b) a clear and unrestricted view of the area of operation;

(c) safe access to and egress from the cabin, including situations where the operator is taken ill.

An example is shown below.



(Photo: Robert Carr, <http://myconstructionphotos.smugmug.com>)

Concrete work equipment

7.9.1. Concrete mixers should be protected by side railings to prevent workers from passing under the skip while it is raised.

7.9.2. Hoppers into which a person could fall, and revolving blades of trough or batch-type mixers, should be adequately guarded by grating.

7.9.3. In addition to the operating brake, skips of concrete mixers should be provided with a device or devices by which they can be securely blocked when raised.

7.9.4. While the drum of a concrete mixer is being cleaned, adequate precautions should be taken to protect the workers inside by locking switches open, removing fuses or otherwise cutting off the power.



(Photo: Richard Neale. Project in Dar es Salaam)

7.9.5. Concrete buckets for use with cranes and aerial cableways should be free as far as practicable from projections from which accumulations of concrete could fall.



[Source of image: www.elcosh.org/images. The ILO is grateful for the use of this image]

“No fall protection, no tag line on cement hopper”

7.9.9. Concrete bucket towers and masts with pouring gutters or conveyor belts should:

- (a) be erected by competent persons;*
- (b) be inspected daily.*

7.9.12. Guides for the bucket should be correctly aligned and so maintained as to prevent the bucket from jamming in the tower.

Pressure plant

Hazards from pressure plant are powerfully illustrated by the incident reported on the following web page:

<http://www.nytimes.com/1988/04/27/nyregion/4-hurt-in-air-compressor-explosion-at-manhattan-construction-site.html>

“Four Hurt in Air Compressor Explosion at Manhattan Construction Site

Three pedestrians and a construction worker were injured yesterday when an air compressor hose exploded at a construction site on the Avenue of the Americas, hurling debris into the street and starting a small fire.

New York City officials said the accident was the second one involving such a compressor in less than a month, and they ordered an immediate inspection of all similar machines in use throughout the city. The trailer-like compressors, which power pneumatic tools through a network of air hoses, are typically parked at curbside near city construction sites, placing them close to sidewalk crowds.

"The machinery is a type commonly used during excavation and other foundation work," said the city's Commissioner of Buildings, Charles M. Smith Jr. "Starting tomorrow, we're going to inventory all of the construction sites in the foundation and excavation stage where this kind of heavy compressor would be used, and ask the construction company or their lessors to inspect the equipment."

Mr. Smith said a hose carrying air from the compressor burst about 10 feet from the diesel-powered compressor.

"The rupture of the hose sent out a concussion wave that spread to the other side of the street, knocking down pedestrians," Mr. Smith said. "The hose itself was blown to pieces, and one of the fragments struck a pedestrian."

A police spokesman, Detective Vincent Jones, said the explosion had ignited some nearby diesel fuel, causing a fire.

Although city investigators had not yet completed an examination of the machine, Mr. Smith said the rupture had apparently resulted from a sudden increase in pressure or a flaw in the hose, which was made of a hard composition rubber lining reinforced by wire strands and covered by a fiber shell.

City investigators found no safety violations in the operation of the machine, and no summonses were issued, Mr. Smith said."

(The extract above is 316 words long, which is less than 400 words and so it is reproduced under the convention of “fair use”)

7.10.1. *Pressure plant and equipment should be examined, tested and issued with a certificate by a competent person in cases and at times prescribed by national laws or regulations.*

7.10.2. *National laws or regulations should be laid down and enforced as regards the materials, design, construction, installation, inspection, testing, maintenance and operation of steam boilers and other pressure plant as necessary.*



[Source of image: www.elcosh.org/images. The ILO is grateful for the use of this image]

“Workers are using respiratory protection. Exposure levels would be reduced if they were using jackhammers and compressors that reduced noise and silica dust levels.”

7.10.4. *Compressors should be equipped with:*

- (a) automatic devices that will prevent the maximum safe discharge pressure from being exceeded;*
- (b) a quick-release valve;*
- (c) suitable arrangements for preventing contamination where persons are working in confined spaces.*

7.10.5. *Compressors in which explosive mixtures of gas may form should be protected against sparking.*

7.10.6. *Where compressor cylinders are equipped with water-cooling jackets it should be possible to observe the water flow.*

7.10.7. *Intercoolers and aftercoolers should be able to withstand safely the maximum pressure in the air-discharge piping.*

7.10.8. *Where necessary to prevent danger, air-discharge piping of compressors should be provided with:*

(a) a fusible plug;

(b) insulating covers to protect workers against burns, and to prevent fire risks.

7.10.9. *Where necessary to prevent danger, an oil separator should be provided between the compressor and the air receiver.*

7.10.10. *Where stop valves are installed in air-discharge piping:*

(a) they should be easily accessible for inspection and cleaning;

(b) one or more safety valves should be installed between the compressor and the stop valve.

7.10.11. *All working parts, including speed governors, safety valves and oil separators, should be inspected and cleaned at suitable intervals.*

7.10.12. *Air receivers should be equipped with:*

(a) a safety valve;

(b) a pressure gauge;

(c) a drain cock.

7.10.13. *Air receivers should be provided with suitable openings for inspection and cleaning.*

7.10.14. *Air receivers should be examined and tested at appropriate intervals by a competent person.*

7.10.15. *The safe working pressure should be marked in a distinctive colour on the pressure gauge.*

7.10.16. *Where necessary to prevent danger, a pressure-reducing valve or a stop valve, or both, should be inserted in the piping between the air receiver and the compressor.*

7.10.17. *Between the receiver and each consuming appliance there should be a stop valve.*

7.10.18. *Cylinders for compressed, dissolved or liquefied gases should be properly constructed with sound material, fitted with appropriate safety devices in accordance with national laws or regulations, inspected and tested by a competent person as prescribed and stored, transported, handled and used in conformity with the prescribed safety measures.*

Power generators

7.13.1. *Power generators should meet national laws and regulations for safe and reliable operation.*

7.13.2. *Power generators should be rated to meet the maximum anticipated load.*

7.13.3. *Power generators should be located in enclosed and properly ventilated areas.*

7.13.4. *Power generators should be provided with an overriding power switch to avoid accidental remote starting during maintenance.*

7.13.5. *Power generators should be provided with adequate silencers and exhaust piping.*

7.13.6. *When located near workers' accommodation, power generators should be housed in a concrete room or properly insulated area in accordance with national laws and regulations to minimise noise disturbance*

4 HAND TOOLS

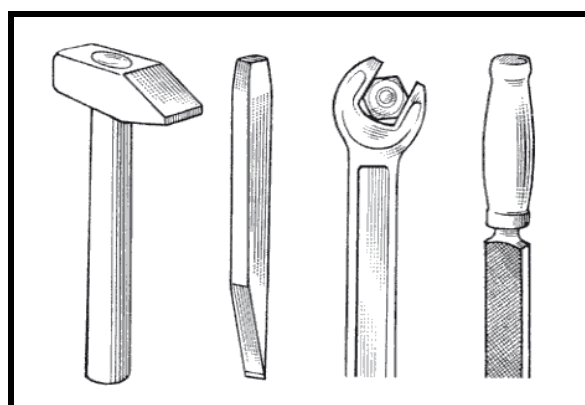
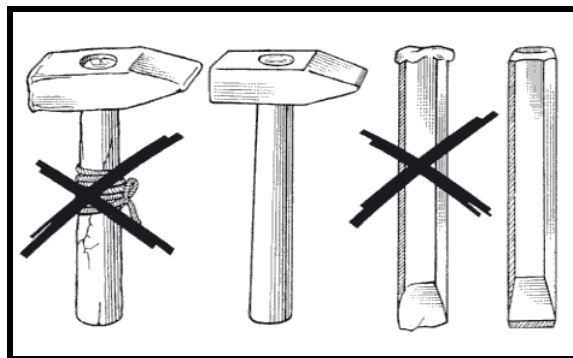

The following organisation offers a downloadable information sheet which provides an excellent introduction to the choice and use of hand tools:

The Center for Construction Research and Training ([www.cpwr](http://www.cpwr.com)): “Choosing Safer Hand Tools in Construction”. Also on this web site are some excellent images, which can be freely downloaded: see <http://www.elcosh.org/images/>

Small tools

7.2.1. Hand tools and implements should be tempered, dressed and repaired by competent persons.

7.2.2. The cutting edges of cutting tools should be kept sharp.

7.2.3. Heads of hammers and other shock tools should be dressed or ground to a suitable radius on the edge as soon as they begin to mushroom or crack.

7.2.4. When not in use and while being carried or transported sharp tools should be kept in sheaths, shields, chests or other suitable containers.

7.2.5. Only insulated or non-conducting tools should be used on or near live electrical installations if there is any risk of electrical shock.

7.2.6. Only non-sparking tools should be used near or in the presence of flammable or explosive dusts or vapours.

Pneumatic tools

7.3.1. Operating triggers on portable pneumatic tools should be:

(a) so placed as to minimise the risk of accidental starting of the machine;

(b) so arranged as to close the air inlet valve automatically when the pressure of the operator's hand is removed.

7.3.2. Hose and hose connections for compressed-air supply to portable pneumatic tools should be:

(a) designed for the pressure and service for which they are intended;

(b) fastened securely to the pipe outlet and equipped with a safety chain, as appropriate.

7.3.3. Pneumatic shock tools should be equipped with safety clips or retainers to prevent dies and tools from being accidentally expelled from the barrel.

7.3.4. Pneumatic tools should be disconnected from power and the pressure in hose lines released before any adjustments or repairs are made.

Cartridge-operated tools

7.4.1. *Whenever practicable, a low-velocity tool should be used.*

7.4.2. *Cartridge-operated tools should have:*

(a) a guard or protective shield that cannot be removed without rendering the tool inoperative;

(b) a device that prevents the tool from firing inadvertently, for example if it is dropped or while it is being loaded;

(c) a device that prevents the tool from firing if it is not approximately perpendicular to the working surface;

(d) a device that prevents the tool from firing if the muzzle is not pressed against the working surface.

7.4.3. *The recoil of a cartridge-operated tool should not be capable of injuring the user.*

7.4.4. *The noise of the detonation should not be such as to damage hearing.*

7.4.5. *A cartridge-operated tool, before each occasion of use, should be inspected to ensure that it is safe to use, and in particular:*

(a) that the safety devices are in proper working order;

(b) that the tool is clean;

(c) that all moving parts work easily;

(d) that the barrel is unobstructed.

7.4.6. *At intervals recommended by the manufacturer the tool should be completely dismantled and inspected for wear on the safety devices by a competent person.*

7.4.7. *Cartridge-operated tools should only be repaired by the manufacturer or by competent persons.*

7.4.8. *Cartridges should not be stored nor cartridge tools operated:*

(a) in a place or environment where they could explode accidentally;

(b) in an explosive atmosphere.

7.4.9. *When not required for use, inspection or other purpose, cartridge-operated tools should be kept in a suitable container that:*

- (a) is made of suitable material;*
- (b) is clearly marked to indicate its contents;*
- (c) is kept locked when not in use;*
- (d) contains nothing except the tools and cartridges.*

7.4.10. *No cartridge-operated tool should be stored or transported loaded, or left loaded when not in use.*

7.4.11. *Cartridge-operated tools should be accompanied by instructions for their maintenance and use and should only be operated by persons trained in their safe use.*

Electrical tools



[Photo: Richard Neale. Permission granted by the operator (Diane Neale)]

7.5.1. *Portable electrical tools should generally be used on reduced voltage to avoid as far as possible the risk of a lethal shock.*

7.5.2. *All electrical tools should be earthed, unless they are "all insulated" or "double insulated" tools which do not require an earth. Earthing should be incorporated in metallic cases, and as a safeguard against damaged cables where wires enter the tool.*

7.5.3. *All electrical tools should receive inspection and maintenance on a regular basis by a competent electrician, and complete records kept.*

Woodworking machines

7.6.1. Shavings, sawdust, etc, should not be removed by hand from woodworking machines or in their vicinity while the machines are working.

7.6.2. Where provided, chip and sawdust extraction systems should be maintained in efficient working order.

7.6.3. Mechanical feeding devices should be used whenever practicable.

7.6.4. All cutters and saw blades should be enclosed as far as practicable.

7.6.5. Circular saws should be provided with strong, rigid and easily adjustable hood guards for the saw blades and with riving knives of suitable design matched to the saw blade in use. The width of the opening in the table for the saw blade should be as small as practicable.

7.6.6. Portable circular saws should be so designed that when the blade is running idle it is automatically covered.

7.6.7. On band saws all the blade, except the operating portion, should be enclosed. Band wheels should be enclosed with stout guards.

7.6.8. Band saws should be provided with automatic tension regulators.

7.6.9. Planing machines should be provided with bridge guards covering the full length and breadth of the cutting block and easily adjustable in both horizontal and vertical directions.

7.6.10. Thicknessing machines should be provided with sectional feed rollers or a kick-back preventer which should be kept as free as possible.

7.6.11. Woodworking machines should be properly spaced to avoid accidental injury when handling large boards or long planks.

5 SCAFFOLDING MATERIALS AND EQUIPMENT

4.2.1. Sufficient suitable and sound material should be provided and used in the construction of scaffolds.



Photo: Richard Neale

A good example is the scaffolding above, which is a patented system which can be erected more quickly and cheaply than conventional ‘tube and fittings’ when used in straightforward applications (such as rectangular scaffolds on firm and level foundations). The whole scaffold is enclosed in sheeting to protect the workforce from weather and the public from falling objects, dust and debris.

The photographs below show how the system is built up from yellow plastic base plates to prevent damage to the pavement surface. The screwed base members are necessary to adjust for irregularities in the level of the pavement because the joints in the uprights are at fixed intervals. The scaffold bracing is part of the patented system. The uprights are encased in highly visible plastic foam to prevent damage to passing pedestrians.



As shown below, a beam is necessary over shop doorways and this is attached by conventional tube and fittings.



4.2.2. Timber used in the construction of scaffolds should be straight-grained, sound, and free from large knots, dry rot, worm holes and other defects likely to affect its strength.

4.2.3. No rope which is defective whether through contact with acids or other corrosive substances or otherwise should be used on scaffolds.

4.2.4. Where necessary, boards and planks used for scaffolds should be protected against splitting.

This is important to preserve the strength of the board and also to prevent injury from jagged ends



(Photo: Richard Neale)

4.2.5. Ladders, boards and planks used in scaffolds should not be painted so that any defects are visible.

4.2.6. Materials used in the construction of scaffolds should be stored under good conditions and apart from any material unsuitable for scaffolds.

4.2.7. Fastenings on wooden scaffolds should conform with the national laws and regulations or be approved by the competent authority.

4.2.8. All tubes, couplers and fittings used in metal tubular scaffolding should be of a standard and type approved by the competent authority. All couplers and fittings should be free from damage and distortion, and should be maintained in an oiled condition.

4.2.9. Couplers should not cause deformation in tubes. Couplers should be made of drop forged steel or equivalent material.

4.2.10. Tubes should be free from cracks, splits and excessive corrosion and be straight to the eye, and tube ends cut cleanly square with the tube axis.

4.2.11. Alloy and steel tubing should not be intermixed on the same scaffold.

Useful guidance from the State of Montana, USA:

<http://erd.dli.mt.gov/safetyhealth/brochures/scaffold.pdf>

“B. Inspections and Testing of Planks

Wood scaffolds should not be proof tested. This may result in concealed or unrecognized damage that may cause failure later. Wood planks bear a mark, stamp, seal, or other indication of the referenced standard on usage.

Examine the plank for large knots, excessive grain slopes, shakes, decay, and other defects that may render it unfit.

Do not use a scaffold if the planks are bowing more than 1/60 of their span.

Discard the plank upon visible or audible evidence of failure, or if it has an obvious deflection.

Determine the safe load for a plank on its size and species.

Do not use rusty or corroded scaffold equipment, its strength is unknown.

Check for cracks around welds, joints, and circumference.

Check castors for damaged brakes, axles, or stems.

Check manufactured planking for missing hooks, locks, missing rivets, bent side rails, and damaged walking surfaces. If the surface is plywood, check for rotten areas.”

(The extract above is 159 words long, which is less than 400 words and so it is reproduced under the convention of “fair use”. The ILO is grateful to the State of Montana for the use of this extract.)

6 TEMPORARY WORKS FOR CONCRETE AND STEEL

Design and supervision of such works has to be done by qualified engineers and this is beyond the scope of **Construction OS&H**.

7 TRENCH SUPPORT AND EXCAVATION EQUIPMENT

Shafts

9.3.2.5. *All shafts over 30m in depth should have an adequate head frame strong enough to withstand safely the maximum load that it will have to carry and preferably be of open steelwork construction.*

9.3.2.6. *If head frames are of timber, they should be treated to make them fire-resistant.*

9.3.2.7. *Head frames should be earthed or otherwise adequately protected against lightning.*

9.3.2.8. *All landings in shafts should be provided with gates that effectively close the opening to a height of at least 2m.*

9.3.2.9. *Shafts should be equipped with a signalling system that warns the hoisting engineer when a conveyance passes beyond the safe limit of travel.*

9.3.2.10. *Before tunnelling operations are begun from a shaft, two separate signalling or communications systems of different types should be installed.*

9.3.2.11. *The signal code should be posted in the hoisting machine room and at each landing.*

9.3.2.12. *Hoisting machines should be equipped:*

(a) with an adequate brake that will automatically stop and hold the conveyance if the hoisting power fails;

(b) with a reliable depth indicator.

9.3.2.13. *All hoisting machines should be inspected at least once a day by the hoisting engineer.*

9.3.2.14. *Shafts exceeding 30m in depth should have an installation for conveying persons.*

9.3.2.15. *Cages or cars for conveying persons should be equipped with safety gear that automatically holds the cage or car when fully loaded if the suspension rope breaks or becomes slack.*

9.3.2.16. *There should be adequate means of blocking the cage or car at every landing.*

9.3.2.17. *Buckets used for conveying persons in shafts should:*

- (a) have no projections on the outside that could catch in an obstruction;*
- (b) be not less than 1 m deep;*
- (c) be provided with adequate means to prevent them from inadvertently tipping and spinning;*
- (d) not be self-opening.*

9.3.2.18. *Notices should be posted at conspicuous places at the hoisting installation stating:*

- (a) the maximum speed for transporting persons in the shaft;*
- (b) the maximum number of persons and the maximum weight of material that may be safely carried in each conveyance.*

9.3.2.19. *Hoisting operations in shafts should be governed by suitable signals.*

Support of excavations

The excavation below has been supported in a very makeshift way and does not inspire confidence. The use of modern trenching equipment would make it much safer.



Photo: Richard Neale

An excellent web site on support of excavations is provided by www.mabeyhire.co.uk. This site has a wide range of very safety-conscious equipment, explained clearly with good illustrations. A visit is highly recommended.

Large or deep excavations are aspect of construction that requires qualified engineers and it is essential that unqualified people do not try to design, erect or maintain such equipment. A very good paper on the subject emphasises this point: “Earth retaining systems for the shaft excavation of smart tunnel” by Siow Meng, Tan; Chee Siong, Lim and Toong Woh, Chang. Ssp Geotechnics Sdn Bhd (sspg@sspsb.com.my).

International conference and exhibition on trenchless technology and tunneling, 7th – 9th March 2006, Hotel Sheraton, Subang, Subang Jaya, Malaysia. See:

<http://www.sspsb.com.my/images/GEOWEB/Publications/SMART-Earth%20Retaining%20Systems.pdf>.

8 FIRE PREVENTION AND CONTROL EQUIPMENT

Wikipedia provides a good introduction to fire extinguishers:

*“A **fire extinguisher** is an **active fire protection** device used to extinguish or control small fires, often in emergency situations. It is not intended for use on an out-of-control fire, such as one which has reached the **ceiling**, endangers the user (i.e. no escape route, smoke, explosion hazard, etc.), or otherwise requires the expertise of a **fire department**. Typically, a fire extinguisher consists of a hand-held cylindrical **pressure vessel** containing an **agent** which can be discharged to extinguish a **fire**.*

*There are two main types of fire extinguishers: stored pressure and generated pressure. In stored pressure units, the expellant is stored in the same chamber as the **firefighting agent** itself. Depending on the agent used, different propellants are used. With dry chemical extinguishers, **nitrogen** is typically used; water and foam extinguishers typically use air. Stored pressure fire extinguishers are the most common type. Cartridge-operated extinguishers contain the expellant gas in a separate cartridge that is punctured prior to discharge, exposing the propellant to the extinguishing agent. This type is not as common, used primarily in areas such as industrial facilities, where they receive higher-than-average use. They have the advantage of simple and prompt recharge, allowing an operator to discharge the extinguisher, recharge it, and return to the fire in a reasonable amount of time. Unlike stored pressure types, these extinguishers utilize compressed **carbon dioxide** instead of nitrogen, although nitrogen cartridges are used on low temperature (-60F rated) models. Cartridge operated extinguishers are available in dry chemical and dry powder types in the US and in water, wetting agent, foam, and dry powder (ABC, BC, or D) types in the rest of the world.*

*Fire extinguishers are further divided into handheld and cart-mounted, also called wheeled extinguishers. Handheld extinguishers weigh from 0.5 to 14 kilograms (1 to 30 pounds), and are hence easily portable by hand. Cart-mounted units typically weigh 23+ kilograms (50+ pounds). These wheeled models are most commonly found at **construction sites**, **airport runways**, **heliports**, as well as **docks** and **marinas**.”*

(332 words, so ‘fair use’)



(Photo: Richard Neale. The ILO is grateful to the Chair of the Board of Management of Cadwyn Housing Association for permission to use this photo.)

Two types of extinguisher, guidance on their use and also actions to take in case of fire

From the ILO Manual:

Type of fire extinguisher	Action	Suitability and dangers
Pressurized water	Cools fuels rapidly - for fires in ordinary combustible building materials	Conducts electricity - not to be used for live electrical equipment or oil fires
Carbon dioxide	Excludes oxygen	Displaces oxygen when used in confined spaces
Dry chemical powder	Interferes with the combustion process	Re-ignition may occur in overheated liquids such as hot bitumen Use in confined areas may lead to a reduction in visibility Non-conductor of electricity and may be used on live electrical equipment
Foam	Excludes oxygen, limited cooling Forms blanket over flammable liquids	Re-ignition may occur in overheated liquids Conducts electricity - not to be used for live electrical components Gives better control over re-ignition than carbon dioxide and dry powder Better suited to extinguish fire in overheated liquids such as bitumen boilers and oil tanks

9 ELECTRICITY

General provisions

15.1.1. All electrical equipment and installations should be constructed, installed and maintained by a competent person, and so used as to guard against danger.

15.1.2. Before construction is commenced and during the progress thereof, adequate steps should be taken to ascertain the presence of and to guard against danger to workers from any live electrical cable or apparatus which is under, over or on the site.

15.1.3. The laying and maintenance of electrical cables and apparatus on construction sites should be governed by national laws and regulations.

15.1.4. All parts of electrical installations should be of adequate size and characteristics for the power requirements and work they may be called upon to do and in particular they should:

(a) be of adequate mechanical strength to withstand working conditions in construction operations;

(b) not be liable to damage by water, dust or electrical, thermal or chemical action to which they may be subjected in construction operations.

15.1.5. All parts of electrical installations should be so constructed, installed and maintained as to prevent danger of electric shock, fire and external explosion.

15.1.6. The electrical distribution at each site should be via an isolator which cuts off current from all conductors, is readily accessible and can be locked in the "off" position but not locked in the "on" position.

15.1.7. The power supply to all electrical equipment should be provided with means of cutting off current from all conductors in an emergency.

15.1.8. All electrical appliances and outlets should be clearly marked to indicate their purpose and voltage.

15.1.9. When the layout of an installation cannot be clearly recognised, the circuits and appliances should be identified by labels or other effective means.

15.1.10. Circuits and appliances carrying different voltages in the same installation should be clearly distinguished by conspicuous means such as coloured markings.

15.1.11. Adequate precautions should be taken to prevent installations from receiving current at a higher voltage from other installations.

15.1.12. Where necessary to prevent danger, installations should be protected against lightning.

15.1.13. Lines for signalling and telecommunication systems should not be laid on the same supports as medium- and high-voltage lines.

15.1.14. Only flameproof equipment and conductors should be installed in explosive atmospheres or in storeplaces for explosives or flammable liquids.

15.1.15. A notice or notices should be kept exhibited at suitable places:

(a) prohibiting unauthorised persons from entering electrical equipment rooms or from handling or interfering with electrical apparatus;

(b) containing directions as to procedures in case of fire, rescue of persons in contact with live conductors and the restoration of persons suffering from electric shock;

(c) specifying the person to be notified in case of electrical accident or dangerous occurrence, and indicating how to communicate with him.

15.1.16. Suitable warnings should be displayed at all places where contact with or proximity to electrical equipment can cause danger.

15.1.17. Persons having to operate electrical equipment should be fully instructed as to any possible dangers of the equipment concerned.



(Photo: Robert Carr, <http://myconstructionphotos.smugmug.com>)

The worker is standing on the cab of a crawler crane and pushing an electric cable above the crane as it passes underneath

Inspection and maintenance

15.2.1. All electrical equipment should be inspected before it is taken into use to ensure that it is suitable for its proposed use.

15.2.2. At the beginning of every shift, the person using the electrical equipment should make a careful external examination of the equipment and conductors, especially the flexible cables.

15.2.3. Apart from some exceptional cases, work on or near live parts of electrical equipment should be forbidden.

15.2.4. Before any work is begun on conductors or equipment that do not have to remain live:

(a) the current should be switched off by a responsible person;

(b) adequate precautions should be taken to prevent the current from being switched on again;

(c) the conductors or the equipment should be tested to ascertain that they are dead;

(d) the conductors and equipment should be earthed and short-circuited;

(e) neighbouring live parts should be adequately protected against accidental contact.

15.2.5. After work has been done on conductors and equipment, the current should only be switched on again on the orders of a competent person after the earthing and short-circuiting have been removed and the workplace reported safe.

15.2.6. Electricians should be supplied with sufficient adequate tools, and personal protective equipment such as rubber gloves, mats and blankets.

15.2.7. All conductors and equipment should be considered to be live unless there is certain proof of the contrary.

15.2.8. When work has to be done in dangerous proximity to live parts the current should be cut off. If for operational reasons this is not possible, the live parts should be fenced off or enclosed by qualified staff from the power station concerned.

Testing

15.3.1. Electrical installations should be inspected and tested and the results recorded in accordance with national laws or regulations.

15.3.2. Periodic testing of the efficiency of the earth leakage protective devices should be carried out.

15.3.3. Particular attention should be paid to the earthing of apparatus, the continuity of protective conductors, polarity and insulation resistance, protection against mechanical damage and condition of connections at points of entry.

10 RELEVANT ELEMENTS OF THE KNOWLEDGE BASE

Title	ILO Code of Practice: Safety & health in construction
Type of source	Code of practice, 174 pages
Publication or other source details	ILO Publications http://www.ilo.org/global/Publications
Date & ISBN/ISSN	1992. 92-2-107104-9
Summary of contents	<p><i>"It goes a long way in mapping out the agenda for health and safety professionals in this most dangerous and populous industry."</i></p> <p>Content:</p> <ol style="list-style-type: none"> 1. General provisions 2. General duties 3. Safety of workplaces 4. Scaffolds and ladders 5. Lifting appliances and gear 6. Transport, earth-moving and materials-handling equipment 7. Plant, machinery, equipment and hand tools 8. Work at heights including roof work 9. Excavations, shafts, earthworks, underground works and tunnels 10. Cofferdams and caissons and work in compressed air 11. Structural frames, formwork and concrete work 12. Pile-driving 13. Work over water 14. Demolition 15. Electricity 16. Explosives 17. Health hazards, first aid and occupational health services 18. Personal protective equipment and protective clothing 19. Welfare
Comments on relevance	This Code of Practice is fundamental to this training package. It has influenced the structure and informed the content.
Other information	Downloaded as "ILO Code of Practice"

Title	ILO Safety, health and welfare on construction sites A training manual
Author(s)	ILO
Type of source	Training manual, 134 pages
Publication or other source details	ILO Geneva, International Labour Office Can be downloaded from: http://www.ilo.org/public/english/protection/safework/training/english/download/architecture.pdf
Date & ISBN/ISSN	1995. ISBN 92-2-109182-1
Summary of contents	Preface 1. Introduction 2. Safety organization and management 3. Site planning and layout 4. Excavations 5. Scaffolding 6. Ladders 7. Hazardous processes 8. Vehicles 9. Movement of materials 10. Working positions, tools and equipment 11. The working environment 12. Personal protective equipment (PPE) 13. Welfare facilities Annexes 1. Safety, health and welfare on construction sites: Check-list 2. The Safety and Health in Construction Convention, 1988 (No. 167), and Recommendation, 1988 (No175)
Comments on relevance	This is a comprehensive manual, which follows the contents of ILO C167 very closely. Extracts have been used in Construct OS&H, especially in the technical sections.
Other information	It has been Downloaded as ILO Safety, health and welfare on construction sites: A training manual